

DIGITAL AIR DATA COMPUTER

AC32 RVSM WITH AOA INPUT (OPTIONAL)

THOMMEN
AIRCRAFT EQUIPMENT



GENERAL

THOMMEN is a leading manufacturer of Air Data Systems and aircraft instruments that are used worldwide on many aircraft types. These include helicopters, corporate turbine aircraft and commercial airliners.

A recent innovation introduced the AC32 Digital Air Data Computer to the Aviation market. The AC32 has integrated vibrating cylinder pressure sensors that give very high degree of accuracy and stability for pitot and static ports.

The AC32 easily complies with the 1000 ft. vertical separation-minimums required for aircraft to operate in RVSM airspace.

In fact, it providing up to 2x16 SSEC curves which makes it quite unique among all Air Data Computers in the market today.

The highly commended THOMMEN AC32 Digital Air Data Computer exceeds the FAA Technical Standard Order (TSO) requirements for accuracy.

The computed air-data parameters are transmitted via the configurable ARINC 429 interface data bus. This has two ARINC 429 transmit and receive-channels where you can adjust the baro-setting.

The AC32 meets the requirements for multiple platforms. This includes TAWS, ACAS/TCAS, EGPWS or FMS systems. It also supports the Air Data for enhanced safety infrastructure capabilities of Transponders. Additionally, an ICAO encoded altitude-output is also available as an option.

The AC32 uses the aircraft standard 28 VDC to guarantee a low consumption of less than 7 watts. The Thommen AC32 also has an extensive Built-In-Test (BIT) that guarantees safe operation.

The low weight of only 2.0 lb (910 grams) is another plus point that optimizes it for use in different state-of-the-art avionic systems. You can easily configure the AC32 for different applications.

ARINC 429 PARAMETERS

* □/○ □ Output
○ ARINC429 accuracy met

Label 203	Pressure Altitude (1013.25mbar)	-1,000	to	+53,000	feet
Label 204/220	Baro Corrected Altitude #1/ #2	-1,000	to	+53,000	feet
Label 212	Vertical Speed	-32,768	to	+32,768	ft/min.
Label 353	Indicated Airspeed IAS	0/20*	to	750	knots
Label 206	Computed Airspeed CAS	0/20*	to	750	knots
Label 210	True Airspeed TAS	0/100*	to	1,000	knots
Label 207	Max. Allowable Airspeed VMO	150	to	750	knots
Label 205	MACH Number	0/0.200*	to	1.200	MACH
Label 211	Total Air Temperature TAT	-60	to	+99	°C
Label 213	Static Air Temperature SAT	-99	to	+60	°C
Label 235/237	Baro Correction #1/ #2	20.67	to	31.48	inHg
Label 234/236	Baro Correction #1/ #2	700	to	1,066	mbar
Label 221/241	AOA	-60°	to	+60°	degree

DIGITAL AIR DATA COMPUTER

AC32 RVSM WITH AOA INPUT (OPTIONAL)



CHARACTERISTICS

FEATURES:	Vibrating Cylinder Pressure Sensors
	RVSM Compliant
	Static Source Error Correction, 2 x 16
	Continuous Built-In-Test
	BIT Failure Memory
RS232 Maintenance Interface	

SIGNAL INPUTS:	Primary Power 28 VDC (< 7 Watts)
	Emergency Power 28 VDC
	ARINC 429 Serial Data Bus, 2 Receive Channels
	TAT Probe 500 Ω @ 0°C (Optional 50 Ω)
	AOA Sensor Input (2 KΩ)

SIGNAL OUTPUTS:	Encoded Altitude ICAO Per TSO C-88a
	Warning Flag Valid 28 VDC
	ARINC 429 Serial Data Bus, 2 Transmit Channels

OPERATING SPECIFICATIONS:	Altitude Scale Error
	-1,000 to 20,000 feet ±10 feet
	-20,000 to 29,000 feet ±20 feet
	-29,000 to 41,000 feet ±30 feet
	41,000 to 53,000 feet ±50 feet
	FAA TSO-C106
	FAA TSO-C88a
	RTCA/DO-178B Level A
RTCA/DO-160D	
- Operating Temperature -55 ... 70 °C	
- Storage Temperature -55 ... 85 °C	
Reliability: MTBF 21,000 hours (est.)	

INTERNAL BLOCK DIAGRAM

AC32 Digital Air Data Computer

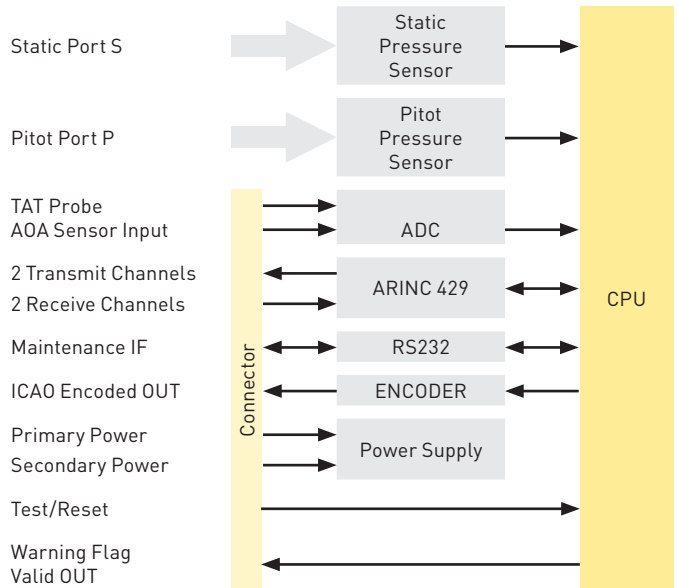

DATA COMMUNICATION BLOCK DIAGRAM

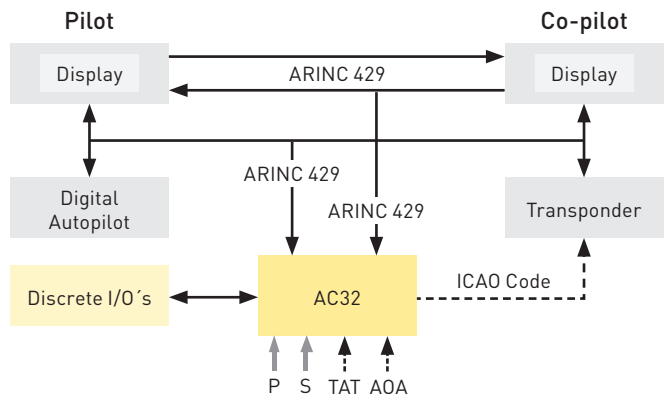

MECHANICAL DRAWING

